

Stipite di compensazione Imperial - 30 mm fresature UNI

LARGHEZZA STIPITE	ALTEZZA	SPESSORE	CODICE ARTICOLO
120	2170	30	16497
240	2170	30	16496
320	2170	30	16495
320	3050	30	16494

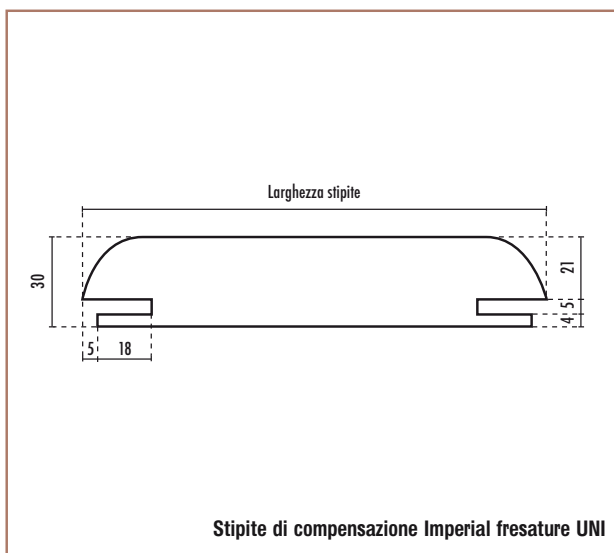

Stipite "P" per rototraslante - asta singola

LARGHEZZA STIPITE "P"	SPESSORE STIPITE "C"	ALTEZZA	CODICE ARTICOLO
45	50	2200	16443/2200

